

Internal Grinding Stone Quill

We can achieve higher precision grinding work to maintain the high. Our Quill is made under the both side centering cylindrical grinding method. It is applicable the wide range of internal grinding and jig grinding.



Example of internal grinding

Product Quill : BZY 230M10GV 15x16xM6

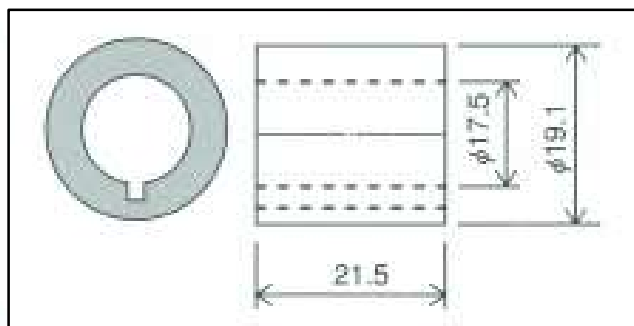

Work material : SCr

Work hardness : HRC50-60

Stock removal : Ø0.15 - Ø0.37 mm

Grinding time : 18 Sec.

Surface : Rz0.6

Roundness : less 3µm

Cylindricity : 3 µm

Dressing interval : 80 pcs.

Head Office & Factory : 101 Moo 1, Hi-Tech Industrial Estate, Asian Highway K.M.59-60, Banlen,
Bang Pa In, Ayutthaya 13160 Phone : +66 (0) 3535 - 0766 - 8
E-Mail : fsksale@fskt.co.th

Chonburi Branch : 29/9-10 Moo7, Tambol Na Pa, Amphur Muang Chonburi, Chonburi 20000
Phone : 038 - 441427 - 8 E-Mail : fsktbpk@fskt.co.th



FUJISEIKO (THAILAND) CO.,LTD.

www.fujiseikothailand.com